

G3612 with ADEM™ A4 Gas Engine

2796-2983 bkW (3750-4000 bhp) @ 1000 rpm
0.5 g/bhp-hr NOx (NTE)

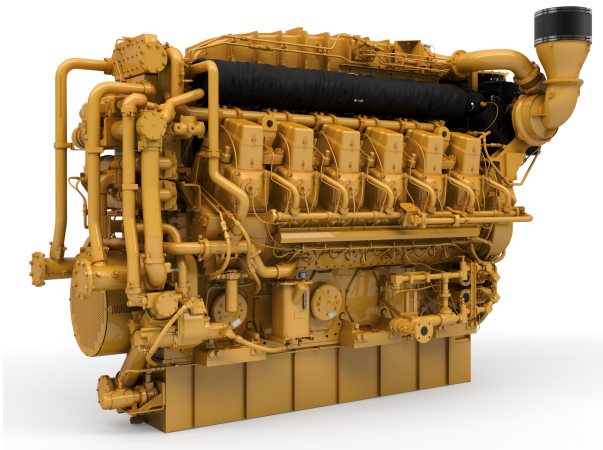

Shown with optional equipment

Cat® Engine Specifications

V-12, 4-Stroke-Cycle

Bore

300 mm (11.8 in)

Stroke

300 mm (11.8 in)

Displacement

254.4 L (15,528 cu. in)

Aspiration

Turbocharged-Aftercooled

Digital Engine Management Governor and Protection

Electronic (ADEM™ A4)

Combustion

Low Emission (Lean Burn)

Cooling System Capacity

Total..... 675 L (178.3 Gal)

JW..... 570 L (150.6 Gal)

SCAC..... 105 L (28 Gal)

Lube Oil System (refill)

1030 L (272 gal)

Oil Change Interval

5000 hours

Rotation (from flywheel end)

Counterclockwise

Flywheel Teeth

255

FEATURES AND BENEFITS

Engine Design

- Industry-leading power with ambient-based rating capability
- ADEM A4 engine control system provides complete engine control, monitoring, and protection while maintaining emissions.
- Widest fuel tolerance in the industry for application flexibility
- Proven reliability and durability with the lowest owning and operating costs
- Factory-installed thermostats

Emissions

Meets U.S. EPA Spark Ignited Stationary NSPS Emissions for 2010 with the use of an oxidation catalyst

Lean Burn Engine Technology

Lean-burn engines operate with large amounts of excess air. The excess air absorbs heat during combustion reducing the combustion temperature and pressure, greatly reducing levels of NOx. Lean-burn design also provides longer component life and excellent fuel consumption.

Ease of Operation

Side covers on block allow for inspection of internal components

Advanced Digital Engine Management

ADEM A4 engine management system integrates speed control, air/fuel ratio control, and ignition/detonation controls into a complete engine management system. ADEM A4 has improved: user interface, display system, shutdown controls, and system diagnostics.

Full Range of Attachments

Large variety of factory-installed attachments reduces packaging time.

Testing

Every engine is full-load tested to ensure proper engine performance.

BUILT FOR IT.™

Gas Engine Rating Pro (GERP)

GERP is a PC-based program designed to provide site performance capabilities for Cat natural gas engines for the gas compression industry. GERP provides engine data for your site's altitude, ambient temperature, fuel, engine coolant heat rejection, performance data, installation drawings, spec sheets, and pump curves.

Product Support Offered Through Global Cat Dealer Network

- More than 2,200 dealer outlets
- Cat factory-trained dealer technicians service every aspect of your Oil & Gas Engine
- Caterpillar parts and labor warranty
- Preventive maintenance agreements available for repair-before-failure options
- S•O•SSM program matches your oil and coolant samples against Caterpillar set standards to determine:
 - Internal engine component condition
 - Presence of unwanted fluids
 - Presence of combustion by-products
 - Site-specific oil change interval

Over 80 Years of Engine Manufacturing Experience

Over 60 years of natural gas engine production. Ownership of these manufacturing processes enables Caterpillar to produce high quality, dependable products.

- Cast engine blocks, heads, cylinder liners, and flywheel housings
- Machine critical components
- Assemble complete engine

Web Site

For all your Oil & Gas power requirements, visit www.cat.com



Air Inlet System

- Air cleaner — standard duty
- Inlet air adapter

Control System

- ADEM A4 control system — provides electronic governing integrated with air/fuel ratio control and individual cylinder ignition timing control
- Electrical system and instrumentation certified for Class I, Division 2, Group D hazardous location. Includes entire ADEM A4 system and optional control panel

Cooling System

- Compressor oil cooler connections
- Jacket water pump
- Jacket water thermostats and housing
- Aftercooler/oil cooler pump
- Aftercooler/oil cooler thermostats and housing
- Two-stage aftercooler
- Jacket water heater connections
- Standard ANSI connections

Exhaust System

- Dry exhaust manifolds
- Single vertical outlet adapter
- Form fitted soft wrap insulation

Flywheels & Flywheel Housings

- SAE standard rotation

OPTIONAL EQUIPMENT

Air Inlet System

- Heavy-duty air cleaner with precleaners

Charging System

- 35 Amp & 65 Amp charging alternators - CSA Approved

Exhaust System

- Flexible bellows adapters
- Exhaust expander
- Weld flanges

Fuel System

- Fuel filter
- Gas pressure regulator
- Flexible connection

Instrumentation

- LCD display panel
- Color HMI display
- Remote data monitoring and speed control
- Compatible with Cat Electronic Technician (ET) and Data View
- Modbus and Ethernet capable

Fuel System

- Gas admission valves — electronically controlled fuel supply pressure

Ignition System

- A4 control system — senses individual cylinder detonation and controls individual cylinder timing

Lube System

- Crankcase breather —top mounted
- Oil cooler
- Oil filter
- Oil pan drain valve - front and rear

Mounting System

- Engine mounting feet (six total)

Protection System

- Electronic shutoff system with purge cycle
- Crankcase explosion relief valves
- Gas shutoff valve

Starting System

- Air starting system

General

- Paint, Caterpillar yellow
- Single vibration damper with guard

Lube System

- Air or electric motor-driven prelube
- Duplex oil filter
- RH service
- Lube oil makeup system

Mounting System

- Mounting plates (set of six)
- Extra mounting feet (set of two)
- Extra mounting plates (set of two)

Power Take-offs

- Front stub shafts

Starting System

- Air pressure reducing valve

General

- Engine barring device
- Dual vibration damper with guard

Performance Number		EM0755-09	EM0756-07	EM0757-07
Rating	°C (°F)	54 (130)	43 (110)	32 (90)
Engine Power	bkW (bhp)	2796 (3750)	2890 (3875)	2983 (4000)
Engine Speed	rpm	1000	1000	1000
Max Altitude @ Rated Torque and 38°C (100°F)	m (ft)	2588.3 (8501)	2451.3 (8051)	2314 (7600)
Speed Turndown @ Max Altitude, Rated Torque, and 38°C (100°F)	%	25	25	25
Aftercooler Temperature				
Stage 1 (JW)	°C (°F)	88 (190)	88 (190)	88 (190)
Stage 2 (SCAC)	°C (°F)	54 (130)	43 (110)	32 (90)
Emissions (NTE)*				
NO _x	g/bkW-hr (g/bhp-hr)	0.67 (0.5)	0.67 (0.5)	0.67 (0.5)
CO	g/bkW-hr (g/bhp-hr)	2.95 (2.2)	2.95 (2.2)	2.95 (2.2)
CO ₂	g/bkW-hr (g/bhp-hr)	562 (419)	562 (419)	562 (419)
VOC**	g/bkW-hr (g/bhp-hr)	0.33 (0.25)	0.32 (0.24)	0.31 (0.23)
Fuel Consumption ***	MJ/bkW-hr (Btu/bhp-hr)	9.25 (6540)	9.24 (6531)	9.22 (6521)
Heat Balance				
Heat Rejection to Jacket Water	bkW (Btu/min)	695 (39508)	699 (39724)	702 (39930)
Heat Rejection to Oil Cooler	bkW (Btu/min)	331 (18844)	361 (20522)	392 (22265)
Heat Rejection to Aftercooler				
Stage 1 (JW)	bkW (Btu/min)	506 (28779)	519 (29537)	533 (30304)
Stage 2 (SCAC)	bkW (Btu/min)	124 (7074)	177 (10086)	232 (13177)
Heat Rejection to Exhaust LHV To 25°C (77°F)	bkW (Btu/min)	2553 (145179)	2610 (148428)	2668 (151707)
Heat Rejection to Atmosphere	bkW (Btu/min)	306 (17382)	290 (16470)	270 (15341)
Exhaust System				
Exhaust Gas Flow Rate	m ³ /min (scfm)	666.01 (23520)	679.2 (23986)	692.51 (24456)
Exhaust Stack Temperature	°C (°F)	454 (850)	457 (855)	461 (861)
Intake System				
Air Inlet Flow Rate	m ³ /min (scfm)	255.5 (9023)	259.18 (9153)	262.86 (9283)
Gas Pressure	kPag (psig)	400 - 485 (58 - 70)	400 - 485 (58 - 70)	400 - 485 (58 - 70)

All technical data is based on 100% load and speed

* listed as not to exceed

** Volatile organic compounds as defined in U.S. EPA 40 CFR 60, subpart JJJJ

*** ISO 3046/1

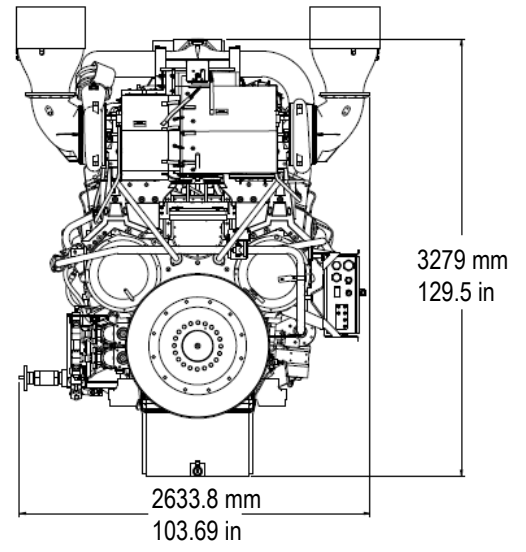
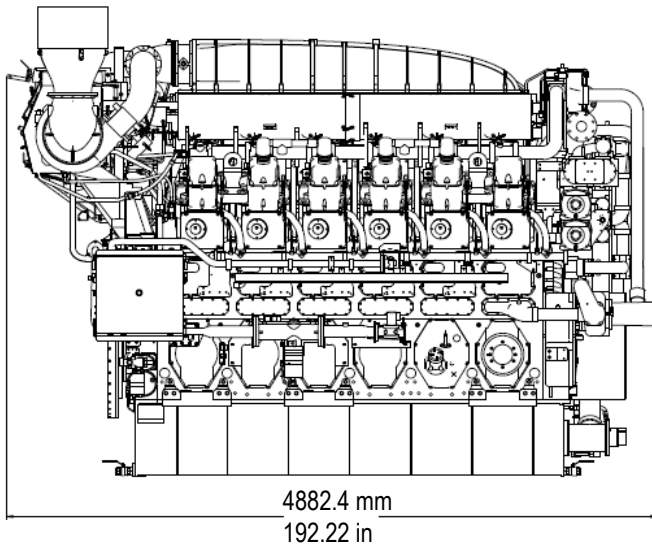

Note: General configuration not to be used for installation

Dimensions		
Length	4882.4 mm	192.22 in
Width	2633.8 mm	103.69 in
Height	3279 mm	129.5 in
Weight	26,535 kg	58,500 lb

Rating Definitions and Conditions

Engine performance is obtained in accordance with SAE J1995, ISO3046/1, BS5514/1, and DIN6271/1 standards.

Conditions: Power for gas engines is based on fuel having an LHV of 33.74 kJ/L (905 Btu/cu ft) at 101 kPa (29.91 in Hg) and 15°C (59°F). Fuel rate is based on a cubic meter at 100 kPa (29.61 in Hg) and 15.6°C (60.1°F). Air flow is based on a cubic foot at 100 kPa (29.61 in Hg) and 25°C (77°F). Exhaust flow is based on a cubic foot at 100 kPa (29.61 in Hg) and stack temperature.

To find your nearest dealer, please visit:
www.cat.com

Subject to change without notice. LEHW0236-01

© 2016 Caterpillar All Rights Reserved.
CAT, CATERPILLAR, their respective logos, "Caterpillar Yellow" and the POWER EDGE trade dress, as well as corporate and product identity used herein, are trademarks of Caterpillar and may not be used without permission.